

Basic principles of vehicle dynamics

A body can only be made to move or change course by the action of forces. Many forces act upon a vehicle when it is being driven. An important role is played by the tires as any change of speed or direction involves forces acting on the tires.

Tires

Task

The tire is the connecting link between the vehicle and the road. It is at that point that the safe handling of a vehicle is ultimately decided. The tire transmits motive, braking and lateral forces within a physical environment whose parameters define the limits of the dynamic loads to which the vehicle is subjected. The decisive criteria for the assessment of tire quality are:

- Straight-running ability
- Stable cornering properties
- Ability to grip on a variety of road surfaces
- Ability to grip in a variety of weather conditions
- Steering characteristics
- Ride comfort (vibration absorption and damping, quietness)
- Durability and
- Economy

Design

There are a number of different tire designs that are distinguished according to the nature and sophistication of the technology employed. The design of a conventional tire is determined by the characteristics required of it in normal conditions and emergency situations.

Legal requirements and regulations specify which tires must be used in which conditions, the maximum speeds at which different types of tire may be used, and the criteria by which tires are classified.

Radial tires

In a radial tire, the type which has now become the standard for cars, the cords of the tire-casing plies run radially, following the shortest route from bead to bead (Fig. 1). A reinforcing belt runs around the perimeter of the relatively thin, flexible casing.

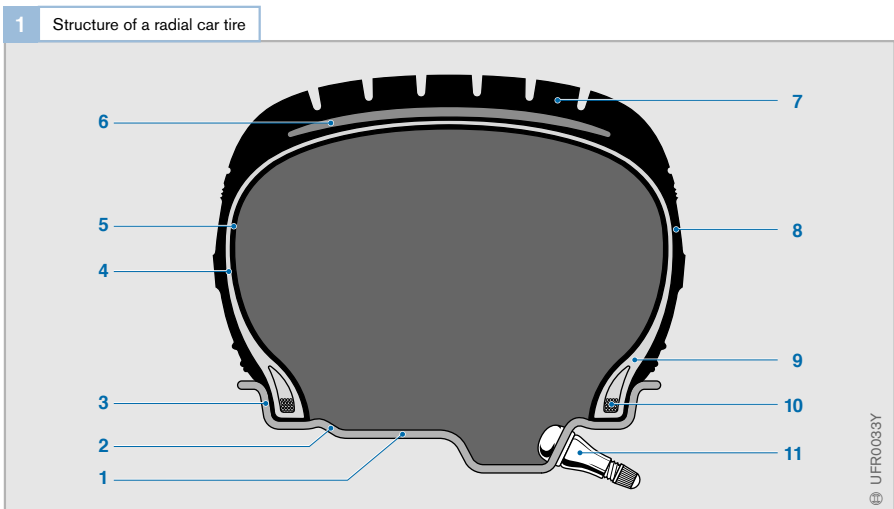

Fig. 1

- 1 Rim bead seat
- 2 Hump
- 3 Rim flange
- 4 Casing
- 5 Air-tight rubber layer
- 6 Belt
- 7 Tread
- 8 Sidewall
- 9 Bead
- 10 Bead core
- 11 Valve

Cross-ply tires

The cross-ply tire takes its name from the fact that the cords of alternate plies of the tire casing run at right angles to one another so that they cross each other. This type of tire is now only of significance for motorcycles, bicycles, and industrial and agricultural vehicles. On commercial vehicles it is increasingly being supplanted by the radial tire.

Regulations

In Europe, the Council Directives, and in the USA the *FMVSS (Federal Motor Vehicle Safety Standard)* require that motor vehicles and trailers are fitted with pneumatic tires with a tread pattern consisting of grooves with a depth of at least 1.6 mm around the entire circumference of the tire and across the full width of the tread.

Cars and motor vehicles with a permissible laden weight of less than 2.8 tonnes and designed for a maximum speed of more than 40 km/h, and trailers towed by them, must be fitted either with cross-ply tires all round or with radial tires all round; in the case of vehicle-and-trailer combinations the requirement applies individually to each unit of the combination. It does not apply to trailers towed by vehicles at speeds of up to 25 km/h.

Application

To ensure correct use of tires, it is important the correct tire is selected according to the recommendations of the vehicle or tire manufacturer. Fitting the same type of tire to all wheels of a vehicle ensures the best handling results. The specific instructions of the tire manufacturer or a tire specialist regarding tire care, maintenance, storage and fitting should be followed in order to obtain maximum durability and safety.

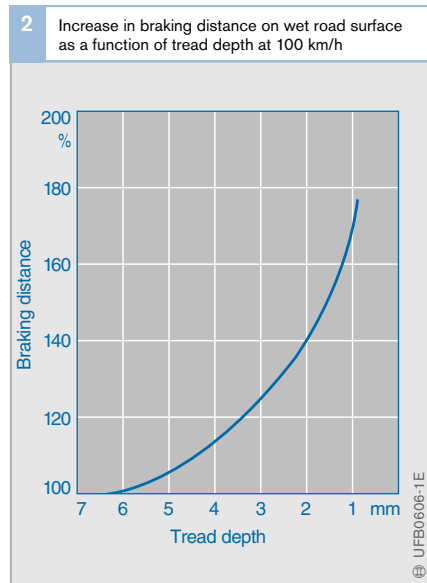

When the tires are in use, i.e. when they are fitted to the wheel, care should be taken to ensure that

- the wheels are balanced so as to guarantee optimum evenness of running,
- all wheels are fitted with the same type of tire and the tires are the correct size for the vehicle,
- the vehicle is not driven at speeds in excess of the maximum allowed for the tires fitted, and
- the tires have sufficient depth of tread.

The less tread there is on a tire, the thinner is the layer of material protecting the belt and the casing underneath it. And particularly on cars and fast commercial vehicles, insufficient tread depth on wet road surfaces has a decisive effect on safe handling characteristics due to the reduction in grip. Braking distance increases disproportionately as tread depth reduces (Fig. 2). An especially critical handling scenario is aquaplaning in which all adhesion between tires and road surface is lost and the vehicle is no longer steerable.

Tire slip

Tire slip, or simply “slip”, is said to occur when there is a difference between the theoretical and the actual distance traveled by a vehicle.

This can be illustrated by the following example in which we will assume that the circumference of a car tire is 2 meters. If the wheel rotates ten times, the distance traveled should be 20 meters. If tire slip occurs, however, the distance actually traveled by the braked vehicle is greater.

Causes of tire slip

When a wheel rotates under the effect of power transmission or braking, complex physical processes take place in the contact area between tire and road which place the rubber parts under stress and cause them to partially slide, even if the wheel does not fully lock. In other words, the elasticity of the tire causes it to deform and “flex” to a greater or lesser extent depending on the weather conditions and the nature of the road surface. As the tire is made largely of rubber, only a proportion of the “deformation energy” is recovered as the tread moves out of the contact area. The tire heats up in the process and energy loss occurs.

Illustration of slip

The slip component of wheel rotation is referred to by λ , where

$$\lambda = (v_F - v_U) / v_F$$

The quantity v_F is the vehicle road speed, v_U is the circumferential velocity of the wheel (Fig. 3). The formula states that brake slip occurs as soon as the wheel is rotating more slowly than the vehicle road speed would normally demand. Only under that condition can braking forces or acceleration forces be transmitted.

Since the tire slip is generated as a result of the vehicle’s longitudinal movement, it is also referred to as “longitudinal slip”. The slip generated during braking is usually termed “brake slip”.

If a tire is subjected to other factors in addition to slip (e.g. greater weight acting on the wheels, extreme wheel positions), its force transmission and handling characteristics will be adversely affected.

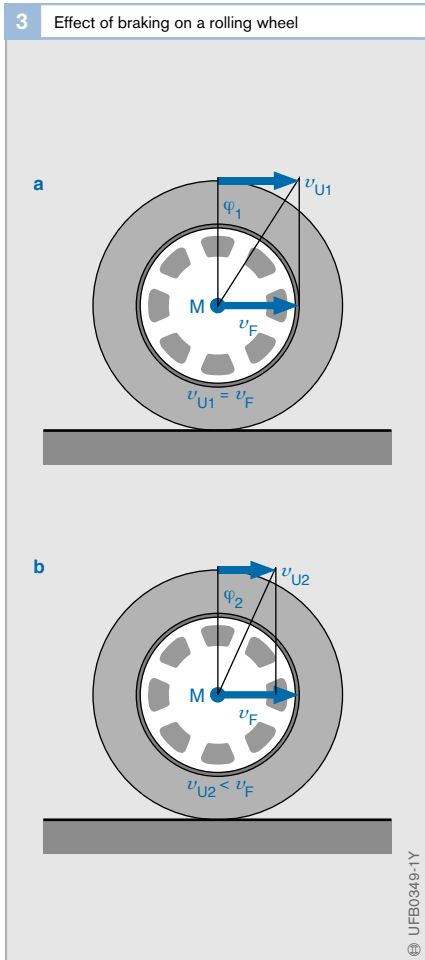

Fig. 3

- a Rolling wheel (unbraked)
- b Braked wheel
- v_F Vehicle speed at wheel center, M
- v_U Circumferential speed

On a braked wheel, the angle of rotation, φ , per unit of time is smaller (slip)

Forces acting on a vehicle

Theory of inertia

Inertia is the property possessed by all bodies, by virtue of which they will naturally maintain the status in which they find themselves, i.e. either at rest or in motion. In order to bring about a change to that status, a force has to be applied to the body. For example, if a car's brakes are applied when it is cornering on black ice, the car will carry on in a straight line without altering course and without noticeably slowing down. That is because on black ice, only very small tire forces can be applied to the wheels.

Turning forces

Rotating bodies are influenced by turning forces. The rotation of the wheels, for example, is slowed down due to the braking torque and accelerated due to the drive torque.

Turning forces act on the entire vehicle. If the wheels on one side of the vehicle are on a slippery surface (e.g. black ice) while the wheels on the other side are on a road surface with normal grip (e.g. asphalt), the vehicle will slew around its vertical axis when the brakes are applied (μ -split braking). This rotation is caused by the yaw moment, which arises due to the different forces applied to the sides of the vehicle.

Distribution of forces

In addition to the vehicle's weight (resulting from gravitational force), various different types of force act upon it regardless of its state of motion (Fig. 1). Some of these are

- forces which act along the longitudinal axis of the vehicle (e.g. motive force, aerodynamic drag or rolling friction); others are
- forces which act laterally on the vehicle (e.g. steering force, centrifugal force when cornering or crosswinds). The tire forces which act laterally on the vehicle are also referred to as lateral forces.

The longitudinal and the lateral forces are transmitted either "downwards" or "sideways" to the tires and ultimately to the road. The forces are transferred through

- the chassis (e.g. wind),
- the steering (steering force),
- the engine and transmission (motive force), or
- the braking system (braking force).

Opposing forces act "upwards" from the road onto the tires and thence to the vehicle because every force produces an opposing force.

1 Forces acting on a vehicle

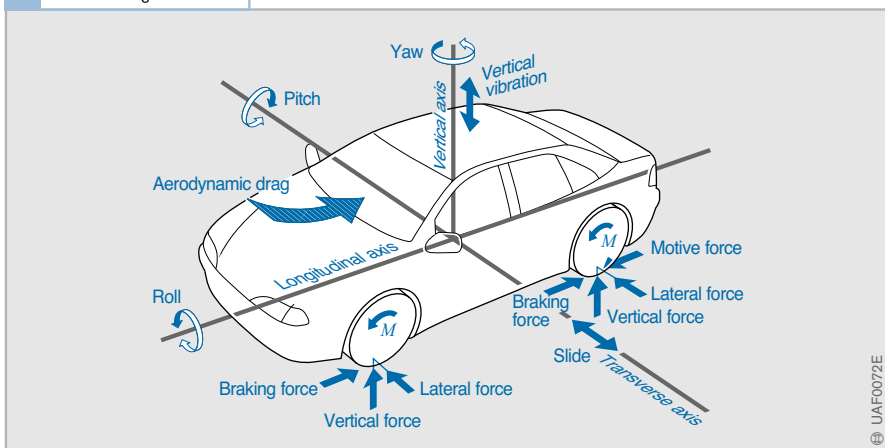

Basically, in order for the vehicle to move, the motive force of the engine (engine torque) must overcome all forces that resist motion (all longitudinal and lateral forces) such as are generated by road gradient or camber.

In order to assess the dynamic handling characteristics or handling stability of a vehicle, the forces acting between the tires and the road, i.e. the forces transmitted in the contact areas between tire and road surface (also referred to as “tire contact area” or “footprint”), must be known.

With more practice and experience, a driver generally learns to react more effectively to those forces. They are evident to the driver when accelerating or slowing down as well as in cross winds or on slippery road surfaces. If the forces are particularly strong, i.e. if they produce exaggerated changes in the motion of the vehicle, they can also be dangerous (skidding) or at least are detectable by squealing tires (e.g. when accelerating aggressively) and increased component wear.

Tire forces

A motor vehicle can only be made to move or change its direction in a specific way by forces acting through the tires. Those forces are made up of the following components (Fig. 2):

Circumferential force

The circumferential force F_U is produced by power transmission or braking. It acts on the road surface as a linear force in line with the longitudinal axis of the vehicle and enables the driver to increase the speed of the vehicle using the accelerator or slow it down with the brakes.

Vertical tire force (normal force)

The vertical force acting downwards between the tire and road surface is called the vertical tire force or normal force F_N . It acts on the tires at all times regardless of the state of motion of the vehicle, including, therefore, when the vehicle is stationary.

The vertical force is determined by the proportion of the combined weight of vehicle and payload that is acting on the individual wheel concerned. It also depends on the degree of upward or downward gradient of the road that the vehicle is standing on. The highest levels of vertical force occur on a level road.

Other forces acting on the vehicle (e.g. heavier payload) can increase or decrease the vertical force. When cornering, the force is reduced on the inner wheels and increased on the outer wheels.

The vertical tire force deforms the part of the tire in contact with the road. As the tire sidewalls are affected by that deformation, the vertical force cannot be evenly distributed. A trapezoidal pressure-distribution pattern is produced (Fig. 2). The tire sidewalls absorb the forces and the tire deforms according to the load applied to it.

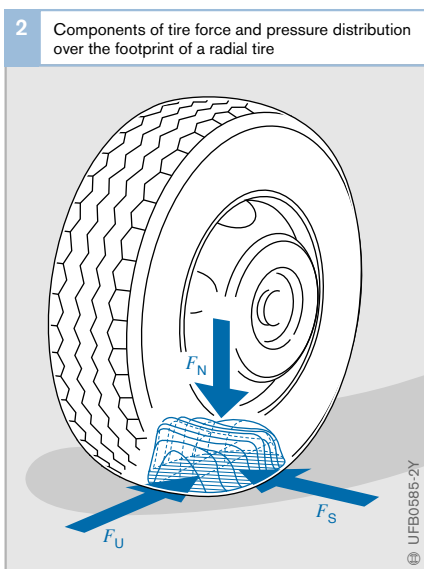

Fig. 2

F_N Vertical tire force, or normal force

F_U Circumferential force (positive: motive force; negative: braking force)

F_S Lateral force

Lateral force

Lateral forces act upon the wheels when steering or when there is a crosswind, for example. They cause the vehicle to change direction.

Braking torque

When the brakes are applied, the brake shoes press against the brake drums (in the case of drum brakes) or the brake pads press against the disks (in the case of disk brakes). This generates frictional forces, the level of which can be controlled by the driver by the pressure applied to the brake pedal.

The product of the frictional forces and the distance at which they act from the axis of rotation of the wheel is the braking torque M_B .

That torque is effective at the circumference of the tire under braking (Fig. 1).

Yaw moment

The yaw moment around the vehicle's vertical axis is caused by different longitudinal forces acting on the left and right-hand sides of the vehicle or different lateral forces acting at the front and rear axles. Yaw moments are required to turn the vehicle when cornering.

Undesired yaw moments, such as can occur when braking on μ -split (see above) or if the vehicle pulls to one side when braking, can be reduced using suitable design measures. The kingpin offset is the distance between the point of contact between the tire and the road and the point at which the wheel's steering axis intersects the road surface (Fig. 3). It is negative if the point at which the steering axis intersects the road surface is on the outside of the point of contact between tire and road. Braking forces combine with positive and negative kingpin offset to create a lever effect that produces a turning force at the steering which can lead to a certain steering angle at the wheel. If the kingpin offset is negative, this steering angle counters the undesired yaw moment.

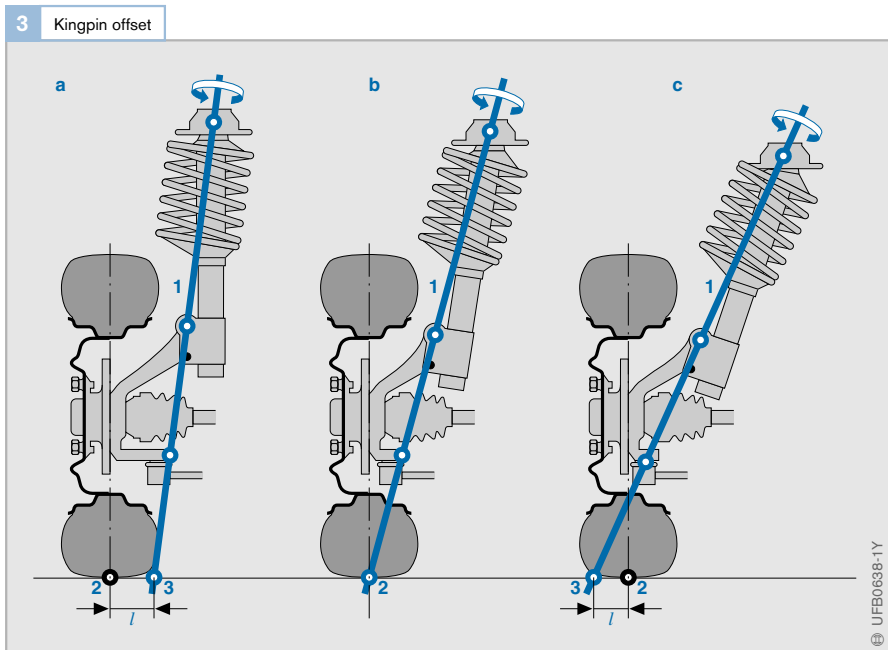

Fig. 3
 a Positive kingpin offset:
 $M_{Ges} = M_T + M_B$
 b Zero kingpin offset:
 no yaw moment
 c Negative kingpin offset:
 $M_{Ges} = M_T - M_B$
 1 Steering axis
 2 Wheel contact point
 3 Intersection point
 l Kingpin offset
 M_{Ges} Total turning force (yaw moment)
 M_T Moment of inertia
 M_B Braking torque

Friction force

Coefficient of friction

When braking torque is applied to a wheel, a braking force F_B is generated between the tire and the road surface that is proportional to the braking torque under stationary conditions (no wheel acceleration). The braking force transmitted to the road (frictional force F_R) is proportional to the vertical tire force F_N :

$$F_R = \mu_{HF} \cdot F_N$$

The factor μ_{HF} is the coefficient of friction. It defines the frictional properties of the various possible material pairings between tire and road surface and the environmental conditions to which they are exposed.

The coefficient of friction is thus a measure of the braking force that can be transmitted. It is dependent on

- the nature of the road surface,
- the condition of the tires,
- the vehicle's road speed, and
- the weather conditions.

The coefficient of friction ultimately determines the degree to which the braking torque is actually effective. For motor-vehicle tires, the coefficient of friction is at its highest on a

clean and dry road surface; it is at its lowest on ice. Fluids (e.g. water) or dirt between the tire and the road surface reduce the coefficient of friction. The figures quoted in Table 1 apply to concrete and tarmac road surfaces in good condition.

On wet road surfaces in particular, the coefficient of friction is heavily dependent on vehicle road speed. At high speeds on less than ideal road surfaces, the wheels may lock up under braking because the coefficient of friction is not high enough to provide sufficient adhesion for the tires to grip the road surface. Once a wheel locks up, it can no longer transmit side forces and the vehicle is thus no longer steerable. Fig. 5 illustrates the frequency distribution of the coefficient of friction at a locked wheel at various road speeds on wet roads.

The friction or adhesion between the tire and the road surface determines the wheel's ability to transmit force. The ABS (Antilock Braking System) and TCS (Traction Control System) safety systems utilize the available adhesion to its maximum potential.

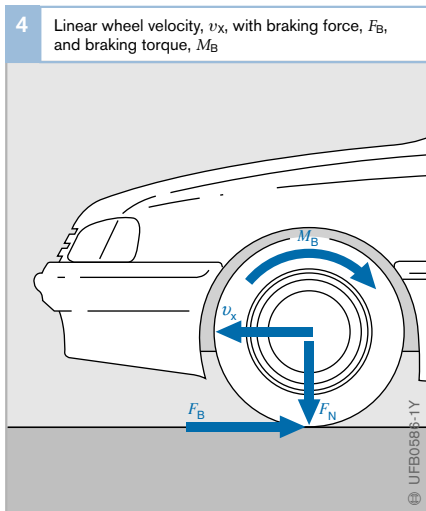
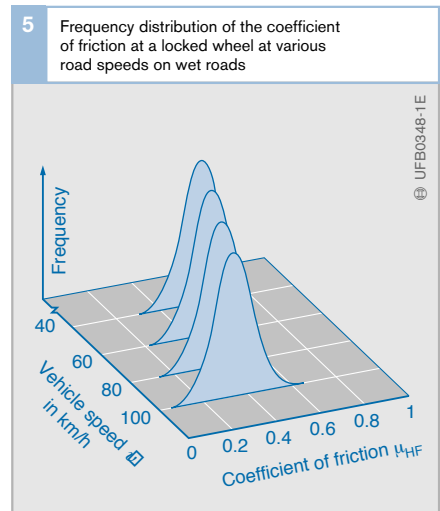

Fig. 4
 v_x Linear velocity of wheel
 F_N Vertical tire force (normal force)
 F_B Braking force
 M_B Braking torque

Fig. 5
 Source:
 Forschungsinstitut für Kraftfahrwesen und Fahrzeugmotoren, Stuttgart, Germany (research institute for automotive engineering and automotive engines)



© UFB0348-1E

Aquaplaning

The amount of friction approaches zero if rainwater forms a film on the road surface on which the vehicle then “floats”. Contact between the tires and the road surface is then lost and the effect known as aquaplaning occurs. Aquaplaning is caused by a “wedge” of water being forced under the entire contact area of the tire with the road surface, thereby lifting it off the ground. Aquaplaning is dependent on:

- the depth of water on the road,
- the speed of the vehicle,
- the tire tread pattern, tire width and level of wear, and
- the force pressing the tire against the road surface.

Wide tires are particularly susceptible to aquaplaning. When a vehicle is aquaplaning, it cannot be steered or braked. Neither steering movements nor braking forces can be transmitted to the road.

Kinetic friction

When describing processes involving friction, a distinction is made between static friction and kinetic friction. With solid bodies, the static friction is greater than kinetic friction. Accordingly, for a rolling rubber tire there are circumstances in which the coefficient of friction is greater than when the wheel locks. Nevertheless, the tire can also slide while it is rolling, and on motor vehicles this is referred to as slip.

Effect of brake slip on coefficient of friction

When a vehicle is pulling away or accelerating – just as when braking or decelerating – the transmission of forces from tire to road depends on the degree of adhesion between the two. The friction of a tire basically has a constant relationship to the level of adhesion under braking or acceleration.

Fig. 6 shows the progression of the coefficient of friction μ_{HF} under braking. Starting from a zero degree of brake slip, it rises steeply to its maximum at between 10% and 40% brake slip, depending on the nature of the road surface and the tires, and then drops away again. The rising slope of the

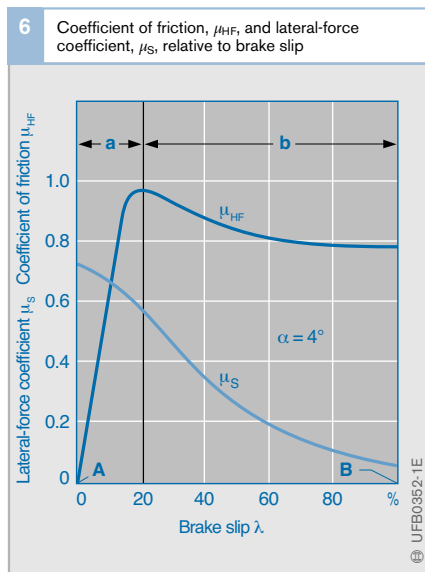

Fig. 6
 a Stable zone
 b Unstable zone
 α Slip angle
 A Rolling wheel
 B Locked wheel

1 Coefficients of friction, μ_{HF} , for tires in various conditions of wear, on various road conditions and at various speeds						
Vehicle road speed	Tire condition	Dry road	Wet road (depth of water 0.2 mm)	Heavy rain (depth of water 1 mm)	Puddles (depth of water 2 mm)	Icy (black ice)
km/h		μ_{HF}	μ_{HF}	μ_{HF}	μ_{HF}	μ_{HF}
50	new	0.85	0.65	0.55	0.5	0.1 and below
	worn out	1	0.5	0.4	0.25	
90	new	0.8	0.6	0.3	0.05	
	worn out	0.95	0.2	0.1	0.0	
130	new	0.75	0.55	0.2	0	
	worn out	0.9	0.2	0.1	0	

Table 1

curve represents the “stable zone” (partial-braking zone), while the falling slope is the “unstable zone”.

Most braking operations involve minimal levels of slip and take place within the stable zone so that an increase in the degree of slip simultaneously produces an increase in the usable adhesion. In the unstable zone, an increase in the amount of slip generally produces a reduction in the level of adhesion. When braking in such situations, the wheel can lock up within a fraction of a second, and under acceleration the excess power-transmission torque rapidly increases the wheel’s speed of rotation causing it to spin.

When a vehicle is traveling in a straight line, ABS and TCS prevent it entering the unstable zone when braking or accelerating.

Sideways forces

If a lateral force acts on a rolling wheel, the center of the wheel moves sideways. The ratio between the lateral velocity and the velocity along the longitudinal axis is referred to as “lateral slip”. The angle between the resulting velocity, v_α , and the forward velocity, v_x , is called the “lateral slip angle α ” (Fig. 7). The side-slip angle, γ , is the angle between the vehicle’s direction of travel and its longitudinal axis. The side-slip angle encountered at high rates of lateral acceleration is regarded as an index of controllability, in other words the vehicle’s response to driver input.

Under steady-state conditions (when the wheel is not being accelerated), the lateral force F_S acting on the center of the wheel is in equilibrium with the lateral force applied to the wheel by the road surface. The relationship between the lateral force acting through the center of the wheel and the wheel contact force F_N is called the “lateral-force coefficient μ_S ”.

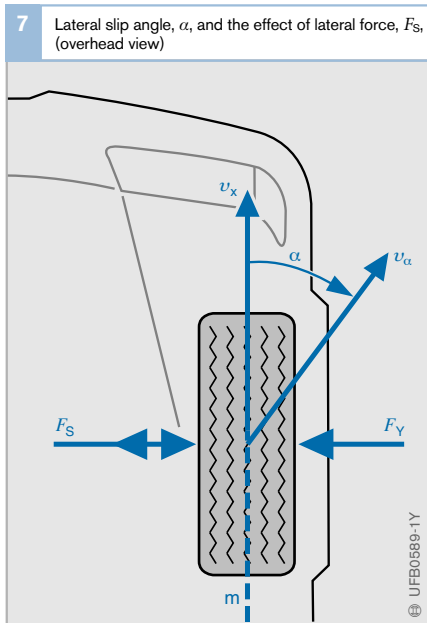

Fig. 7
 v_α Velocity in lateral slip direction
 v_x Velocity along longitudinal axis
 F_S, F_Y Lateral force
 α Slip angle

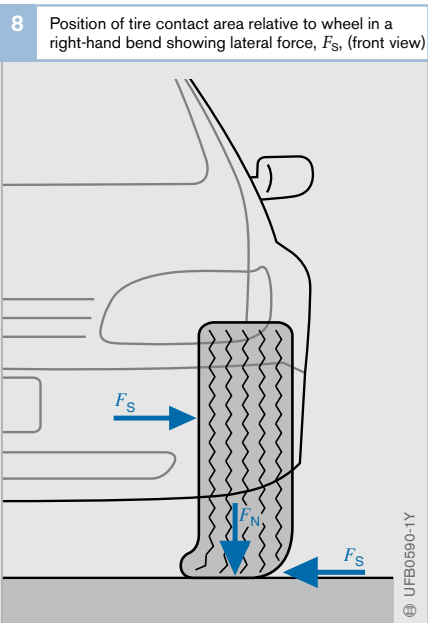

Fig. 8
 F_N Vertical tire force (normal force)
 F_S Lateral force

There is a nonlinear relationship between the slip angle α and the lateral-force coefficient μ_S that can be described by a lateral slip curve. In contrast with the coefficient of friction μ_{HF} that occurs under acceleration and braking, the lateral-force coefficient μ_S is heavily dependent on the wheel contact force F_N . This characteristic is of particular interest to vehicle manufacturers when designing suspension systems so that handling characteristics can be enhanced by stabilizers.

With a strong lateral force, F_S , the tire contact area (footprint) shifts significantly relative to the wheel (Fig. 8). This retards the buildup of the lateral force. This phenomenon greatly affects the transitional response (behavior during transition from one dynamic state to another) of vehicles under steering.

Effect of brake slip on lateral forces

When a vehicle is cornering, the centrifugal force acting outwards at the center of gravity must be held in equilibrium by lateral forces on all the wheels in order for the vehicle to be able to follow the curve of the road.

However, lateral forces can only be generated if the tires deform flexibly sideways so that the direction of movement of the wheel's center of gravity at the velocity, v_w , diverges from the wheel center plane "m" by the lateral slip angle, α (Fig. 7).

Fig. 6 shows the lateral-force coefficient, μ_S , as a function of brake slip at a lateral slip angle of 4° . The lateral-force coefficient is at its highest when the brake slip is zero. As brake slip increases, the lateral-force coefficient declines gradually at first and then increasingly rapidly until it reaches its lowest point when the wheel locks up. That minimum figure occurs as a result of the lateral slip angle position of the locked wheel, which at that point provides no lateral force whatsoever.

Friction – tire slip – vertical tire force

The friction of a tire depends largely on the degree of slip. The vertical tire force plays a subordinate role, there being a roughly linear relationship between braking force and vertical tire force at a constant level of slip.

The friction, however, is also dependent on the tire's lateral slip angle. Thus the braking and motive force reduces as the lateral slide angle is increased at a constant level of tire slip. Conversely, if the braking and motive force remains constant while the lateral slip angle is increased, the degree of tire slip increases.

Dynamics of linear motion

If the rim of a wheel is subjected both to a lateral force and braking torque, the road surface reacts to this by exerting a lateral force and a braking force on the tire. Accordingly, up to a specific limit determined by physical parameters, all forces acting on the rotating wheel are counterbalanced by equal and opposite forces from the road surface.

Beyond that limit, however, the forces are no longer in equilibrium and the vehicle's handling becomes unstable.

Total resistance to motion

The total resistance to vehicle motion, F_G , is the sum of the rolling resistance, aerodynamic drag and climbing resistance (Fig. 1). In order to overcome that total resistance, a sufficient amount of motive force has to be applied to the driven wheels. The greater the engine torque, the higher the transmission ratio between the engine and the driven wheels and the smaller the power loss through the drivetrain (efficiency η is approx. 0.88...0.92 with engines mounted in line, and approx. 0.91...0.95 with trans-

versely mounted engines), the greater is the motive force available at the driven wheels.

A proportion of the motive force is required to overcome the total resistance to motion. It is adapted to suit the substantial increase in motion resistance on uphill gradients by the use of a choice of lower gearing ratios (multi-speed transmission). If there is a "surplus" of power because the motive force is greater than the resistance to motion, the vehicle will accelerate. If the overall resistance to motion is greater, the vehicle will decelerate.

Rolling resistance when traveling in a straight line

Rolling resistance is produced by deformation processes which occur where the tire is in contact with the road. It is the product of weight and rolling resistance coefficient and increases with a smaller wheel diameter and the greater the degree of deformation of the tire, e.g. if the tire is under-inflated. However, it also increases as the weight on the wheel and the velocity increases. Furthermore, it varies according to type of road surface – on asphalt, for example, it is only around 25% of what it is on a dirt track.

Fig. 1
 F_L Aerodynamic drag
 F_{Ro} Rolling resistance
 F_{St} Climbing resistance
 F_G Total resistance to motion
 G Weight
 α Incline angle/gradient angle
 S Center of gravity

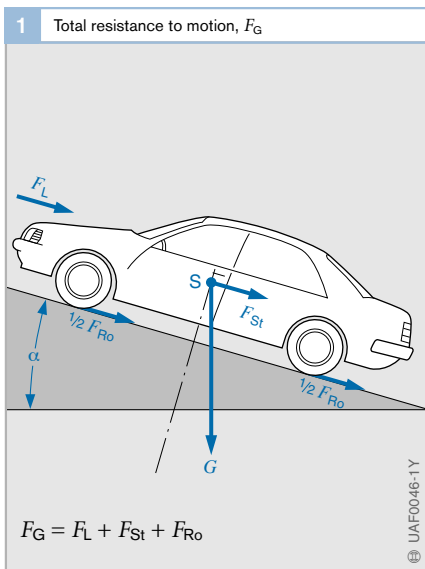

1 Examples of drag coefficient, c_w , for cars

Vehicle body shape	c_w
Convertible with top down	0.5 ... 0.7
Box-type	0.5 ... 0.6
Conventional saloon ¹⁾	0.4 ... 0.55
Wedge shape	0.3 ... 0.4
Aerodynamic fairings	0.2 ... 0.25
Tear-drop	0.15 ... 0.2

¹⁾ "Three-box" design

2 Examples of drag coefficient, c_w , for commercial vehicles

Vehicle body shape	c_w
Standard tractor unit	
– without fairings	≥ 0.64
– with some fairings	0.54 ... 0.63
– with all fairings	≤ 0.53

Table 1
Table 2

Rolling resistance when cornering

When cornering, the rolling resistance is increased by an extra component, cornering resistance, the coefficient of which is dependent on vehicle speed, the radius of the bend being negotiated, suspension characteristics, type of tires, tire pressure and lateral-slip characteristics.

Aerodynamic drag

The aerodynamic drag F_L is calculated from the air density ρ , the drag coefficient c_W (dependent on the vehicle body shape, Tables 1 and 2), vehicle's frontal cross-sectional area A and the driving speed v (taking account of the headwind speed).

$$F_L = c_W \cdot A \cdot v^2 \cdot \rho / 2$$

Climbing resistance

Climbing resistance, F_{St} (if positive), or gravitational pull (if negative) is the product of the weight of the vehicle, G , and the angle of uphill or downhill gradient, α .

$$F_{St} = G \cdot \sin \alpha$$

Acceleration and deceleration

Steady acceleration or deceleration in a straight line occurs when the rate of acceleration (or deceleration) is constant. The distance required for deceleration is of greater significance than that required for acceleration because braking distance has direct implications in terms of vehicle and road safety.

The braking distance is dependent on a number of factors including

- Vehicle speed: at a constant rate of deceleration, braking distance increases quadratically relative to speed.
- Vehicle load: extra weight makes braking distances longer.
- Road conditions: wet roads offer less adhesion between road surface and tires and therefore result in longer braking distances.
- Tire condition: insufficient tread depth increases braking distances, particularly on wet road surfaces.
- Condition of brakes: oil on the brake pads/shoes, for example, reduces the friction between the pads/shoes and the disk/drum. The lower braking force thus available results in longer braking distances.
- Fading: The braking power also diminishes due to the brake components overheating.

The greatest rates of acceleration or deceleration are reached at the point when the motive or braking force is at the highest level possible without the tires starting to lose grip (maximum traction).

The rates actually achievable under real conditions, however, are always slightly lower because the vehicle's wheels are not all at the point of maximum adhesion at precisely the same moment. Electronic traction, braking and vehicle-handling control systems (TCS, ABS and ESP) are active around the point of maximum force transmission.

Dynamics of lateral motion

Response to crosswinds

Strong crosswinds can move a vehicle off course, especially if it is traveling at a high speed and its shape and dimensions present a large surface area for the wind to catch (Fig. 1). Sudden crosswind gusts such as may be encountered when exiting a road cutting can cause substantial sideways movement (yaw) of high-sided vehicles. This happens too quickly for the driver to react and may provoke incorrect driver response.

When a vehicle is driving through a crosswind, the wind force, F_W , produces a lateral component in addition to the longitudinal aerodynamic drag, F_L . Although its effect is distributed across the entire body surface, it may be thought of as a single force, the lateral wind force, F_{SW} , acting at a single point of action “D”. The actual location of the point of action is determined by the vehicle’s body shape and angle of incidence α of the wind.

The point of action is generally in the front half of the vehicle. On conventionally shaped saloon cars (“three-box” design) it is largely static and is closer to the center of the vehicle than on vehicles with a more streamlined body shape (sloping back), where it can move according to the angle of incidence of the wind.

The position of the center of gravity, S, on the other hand depends on the size and distribution of the vehicle load. In view of these variable factors, therefore, in order to arrive at a general representation of the effect of a crosswind (that is not affected by the relative position of the wheels and suspension to the body), a reference point O on the center line of the vehicle at the front is adopted.

When specifying lateral wind force at a reference point other than the true point of action, the turning force of the crosswind around the point of action, that is the yaw moment, M_Z , must also be considered. The crosswind force is resisted by the lateral cornering forces at the wheels. The degree of lateral cornering force which a pneumatic tire can provide depends on various factors in addition to lateral slip angle and wheel load, such as tire design and size, tire pressure and the amount of grip afforded by the road surface.

A vehicle will have good directional stability characteristics in a crosswind if the point of action is close to the vehicle’s center of gravity. Vehicles that tend to oversteer will deviate less from their course in a crosswind if the point of action is forward of the center of gravity. The best position for the point of action on vehicles with a tendency to understeer is slightly behind the center of gravity.

Fig. 1

- D Point of action
 - O Reference point
 - S Center of gravity
 - F_W Wind force
 - F_L Aerodynamic drag
 - F_{SW} Lateral wind force
 - M_Z Yaw moment
 - α Angle of incidence
 - l Vehicle length
 - d Distance of point of action, D, from reference point, O
- F_S and M_Z acting at O corresponds to F_S acting at D (in aerodynamics it is normal to refer to dimensionless coefficients instead of forces)

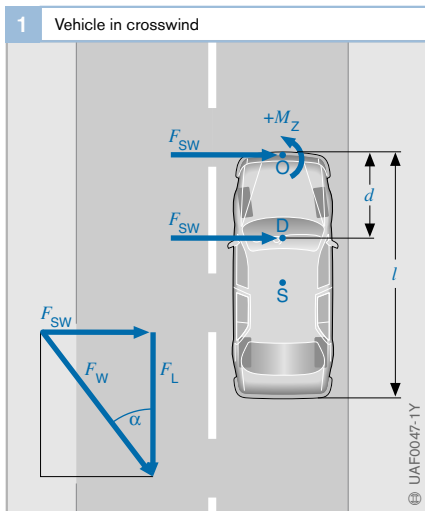

Understeer and oversteer

Cornering forces between a rubber-tired wheel and the road can only be generated when the wheel is rotating at an angle to its plane. A lateral slip angle must therefore be present. A vehicle is said to understeer when, as lateral acceleration increases, the lateral slip angle at the front axle increases more than it does at the rear axle. The opposite is true of a vehicle which oversteers (Fig. 2).

For safety reasons, vehicles are designed to slightly understeer. As a result of drive slip, however, a front-wheel drive vehicle can quickly change to sharply understeer or a rear-wheel drive vehicle to oversteer.

Centrifugal force while cornering

Centrifugal force, F_{cf} , acts at the center of gravity, S, (Fig. 3). Its effect depends on a number of factors such as

- the radius of the bend,
- the speed of the vehicle,
- the height of the vehicle’s center of gravity,
- the mass of the vehicle,
- the track of the vehicle,
- the frictional characteristics of the tire and road surface (tire condition, type of surface, weather conditions), and
- the load distribution in the vehicle.

Potentially hazardous situations will occur when cornering if the centrifugal force reaches a point where it threatens to overcome the lateral forces at the wheels and the vehicle cannot be held on its intended course. This effect can be partially counteracted by positive camber or banked corners.

If the vehicle slips at the front wheel, it understeers; if it slips at the wheel axle, it oversteers. In both cases the Electronic Stability Program (ESP) detects an undesirable rotation about the vertical axle. By active intervention in the form of selective braking of individual wheels, it is then able to correct the imbalance.

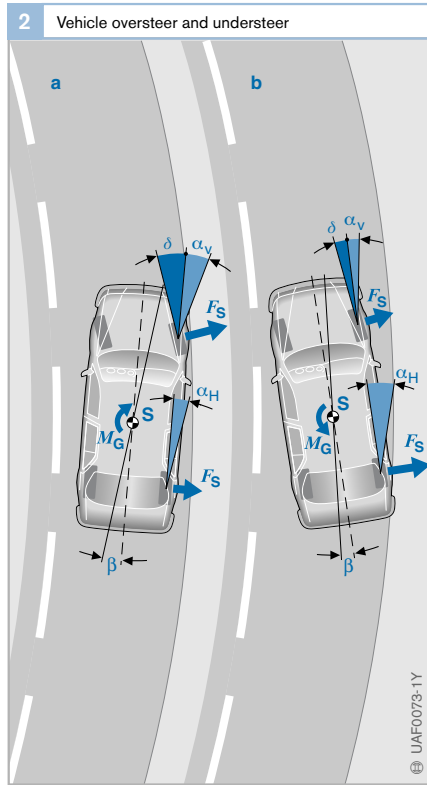

Fig. 2
 a Understeer
 b Oversteer
 α_v Front lateral slip angle
 α_H Rear lateral slip angle
 δ Steering angle
 β Side-slip angle
 F_S Lateral force
 M_G Yaw moment

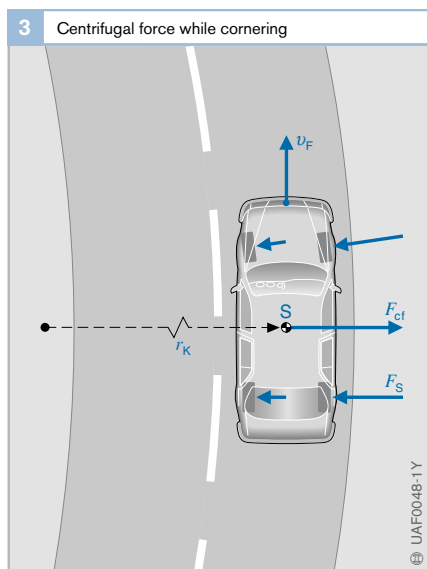

Fig. 3
 F_{cf} Centrifugal force
 v_F Vehicle speed
 F_S Lateral force at individual wheels
 r_K Radius of bend
 S Center of gravity

Definitions

Braking sequence

As defined in ISO 611, the term “braking sequence” refers to all operations that take place between the point at which operation of the (brake) actuation device begins and the point at which braking ends (when the brake is released or the vehicle is at a standstill).

Variable braking

A type of braking system which allows the driver at any time to increase or reduce the braking force to a sufficiently precise degree by operating the actuation device within its normal effective range.

If operating the actuation device in a particular manner increases the braking force, then the opposite action must reverse the effect and reduce the braking force.

Braking-system hysteresis

Braking system hysteresis is the difference between the actuating forces when the brake is applied and released at a constant braking torque.

Brake hysteresis

Brake hysteresis is the difference between the application forces when the brake is actuated and released at a constant braking torque.

Forces and torques

Actuating force

The actuating force, F_C , is the force that is applied to the actuation device.

Application force

On a friction brake, the application force is the total force exerted on the brake-pad mount, together with attached friction material, in order to generate the friction required for the braking force.

Total braking force

The total braking force, F_b , is the sum total of braking forces at each of the wheels that are produced by the effect of the braking system and which oppose the vehicle's motion or its tendency to move.

Braking torque

The braking torque is the product of the frictional forces generated in the brake by the application forces and the distance of the point of action of those forces from the axis of rotation of the wheel.

Braking-force distribution

The braking-force distribution indicates in terms of percentage share how the total braking force, F_b , is distributed between the front and rear wheels, e.g. front wheels 60%, rear wheels 40%.

External brake coefficient, C

The external brake coefficient, C , is the ratio of the output torque to the input torque or the output force to the input force of a brake.

Internal brake coefficient, C^*

The internal brake coefficient, C^* , is the ratio of the total tangential force acting at the effective radius of a brake to the application force, F_S .

Typical values: for drum brakes, values of up to $C^* = 10$ may be obtained, for disc brakes $C^* \approx 1$.

Time periods

The braking sequence is characterised by a number of time periods which are defined with reference to the ideal curves shown in Figure 1.

Period of movement of actuation device

The period of movement of the actuation device is the time from the point at which force is first applied to the actuation device (t_0), to the point at which it reaches its final position (t_3) as determined by the actuating force or the actuation travel. The same applies by analogy to the release of the brakes.

Response time

The response time, t_a , is the time that elapses from the point at which force is first applied to the actuation device to the point at which braking force is first produced (pressure generated in the brake lines) ($t_1 - t_0$).

Pressure build-up time

The pressure build-up time, t_b , is the time from the point at which braking force is first produced to the point at which the pressure in the brake lines reaches its highest level ($t_5 - t_1$).

Total braking time

The braking time, t_b , is the time that elapses from the point at which force is first applied to the actuation device to the point at which braking force ceases ($t_7 - t_0$). If the vehicle comes to a halt, then the moment at which the vehicle is first stationary is the moment at which the braking time ends.

Effective braking time

The effective braking time, t_w , is the time that elapses from the moment at which braking force is first produced to the moment at which braking force ceases ($t_7 - t_2$). If the vehicle comes to a halt, then the moment at which the vehicle is first stationary is the moment at which the effective braking time ends.

Distances

Braking distance

The braking distance, s_1 , is the distance travelled by a vehicle during the period of the effective braking time ($t_7 - t_2$).

Total braking distance

The total braking distance s_0 is the distance travelled by a vehicle during the period of the total braking time ($t_7 - t_0$). That is the distance travelled from the point at which the driver first applies force to the actuation device to the point at which the vehicle is at a standstill.

Braking deceleration

Momentary deceleration

The momentary deceleration, a , is the quotient of the reduction in speed and the elapsed time.
 $a = dv/dt$

Average deceleration over the total braking distance

From the vehicle speed v_0 at the time t_0 , the average deceleration, a_{ms} , over the stopping distance, s_0 , is calculated using the formula
 $a_{ms} = v_0^2/2s_0$

Mean fully developed deceleration

The figure for mean fully developed deceleration, a_{mft} , represents the average deceleration during the period in which deceleration is at its fully developed level ($t_7 - t_6$).

Braking factor

The braking factor, Z , is the ratio between total braking force, F_b and total static weight, G_S , (vehicle weight) acting on the axle or axles of the vehicle. That is equivalent to the ratio of braking deceleration, a , to gravitational acceleration, g ($g = 9.81 \text{ m/s}^2$).

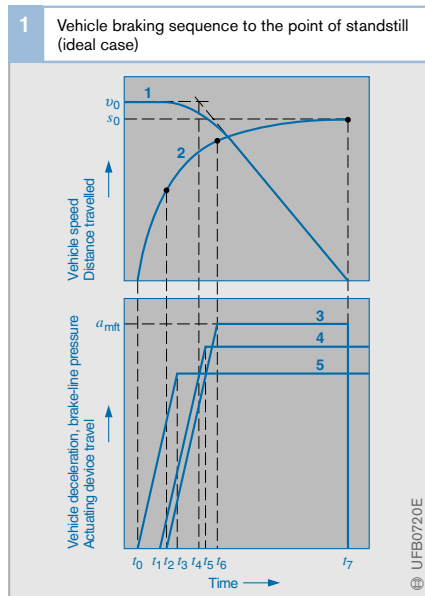

Fig. 1

- 1 Vehicle speed
- 2 Distance travelled while braking
- 3 Vehicle deceleration
- 4 Brake-line pressure (brake pressure)
- 5 Actuation device travel
- t_0 Time at which the driver first applies force to actuation device
- t_1 Brake-line pressure (brake pressure) starts to rise
- t_2 Vehicle deceleration begins
- t_3 Actuation device has reached intended position
- t_4 Intersection of extended speed curve sections
- t_5 Brake-line pressure has reached stabilised level
- t_6 Vehicle deceleration has reached stabilised level
- t_7 Vehicle comes to a halt

© UFEB0720E



<http://www.springer.com/978-3-658-03977-6>

Brakes, Brake Control and Driver Assistance Systems
Function, Regulation and Components

Reif, K. (Ed.)

2014, VIII, 275 p. 306 illus. in color., Softcover

ISBN: 978-3-658-03977-6